

WINE | Upright Cabinets

WINE COOLERS

CW 36DT



DETAILS



Led LED light (BLUE Color)



Digital control



Sliding wooden shelves



Wood shelves



GENERAL FEATURES

- 140 Lt. Wine cellar free-standing installation
- External in black coated plate, black thermoformed internally
- Ventilated Cooling
- Automatic compressor cycle defrost
- Foaming Agent Cyclopentane (35mm per side)
- Digital display control
- Low temperature compensation function
- Removable Gasket
- Interior LED light (Blue Color)
- Reversible door with vertical cylindrical handle
- N.1 charcoal filter fitted as standard
- Opening door alarm
- Double layer safety tempered glass
- Tinted glass door for wine protection
- Adjustable wooden shelves: 4 Pcs + N.1 Bottom
- N.4 Adjustable feet
- Energy efficiency class: G

TECHNICAL SPECIFICATIONS

Capacity	140 L
Temperature	+5°~+10°C/+10°~+18°C
Consumption	0.389 kWh/24h
Rated Power	85 W
Noise level	39
Net Weight	41 Kg
Gross Weight	46 Kg
External Dimensions (WxDxH mm)	493x635x840
Internal Dimensions (WxDxH mm)	422x436x740
Packaging dimensions (WxDxH mm)	550x660x870
Loading quantities 20'/40'/40'HQ	72/150/223

PRODUCT DIMENSIONS

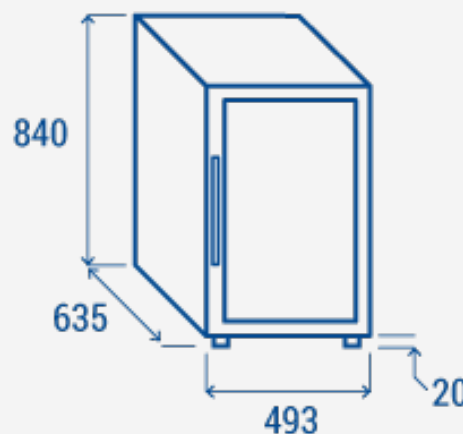

CERTIFICATION

CE RoHS



COOL HEAD EUROPE
We make the world a cooler place



www.coolheadeurope.com